



The Best Value in Zoning Today®

The rectangular damper series are extruded aluminum parallel blade dampers complete with 24V Spring Return Motor. These dampers are shipped complete and ready for installation. The lightweight ZD can be installed in any position in any properly sized duct. These dampers and motor combination are rated for duct pressure up to 1.0" W.C.

Dampers are available all in even sizes from 8"x 8" to 36"x 24". All dampers are 1/4" undersized from their listed size. Dampers are ordered with the motor mounted to the second dimension (height dimension), therefore for bottom mount applications, choose a damper like 101014 that will fit in a 10-inch-tall duct mounted between 16-inch center floor joists. Dampers are ordered as 10wwhh, using 2 digits for each width (ww) and height (hh) dimension. All dampers are shipped in the Open position ready for installation. Contact the factory for sizes above 30"x 6".

All rectangular dampers are shipped as Power Close dampers that are powered closed and spring return opened. The damper motor is also unique in that it can easily be field converted from powered closed to powered open. A 24 Volt AC, 50/60 Hz, spring return damper motor powers the damper. The motor powers the damper closed and spring returns the damper open for fail-safe operation. Providing power to the damper drives the damper closed. Removing power from the motor allows the motor to spring back to the open position.

The 24 Volt, hysteresis, synchronous motor has been tested to over 250,000 cycles to provide long life. Even replacing the motor is a simple less than one (1) minute change by loosening the setscrew holding the motor onto the damper.

The motor also has a simple adjustment for setting the damper to a minimum position. A minimum position allows for excess by-pass air. To set a minimum position, loosen the setscrew, align the setscrew to the minimum position label and re-tighten.

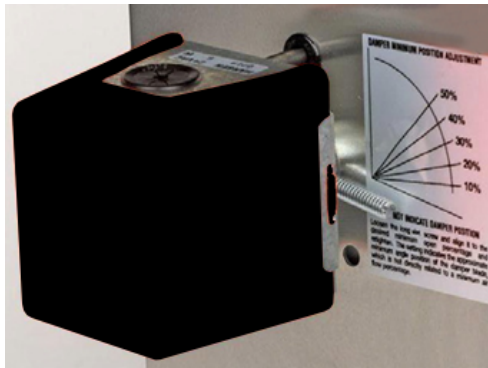

Note: Minimum adjustment does not indicate damper position.

Rectangular Damper with Spring Return Motor



Side Mount



Bottom Mount

Dimensional Drawing (nominal)

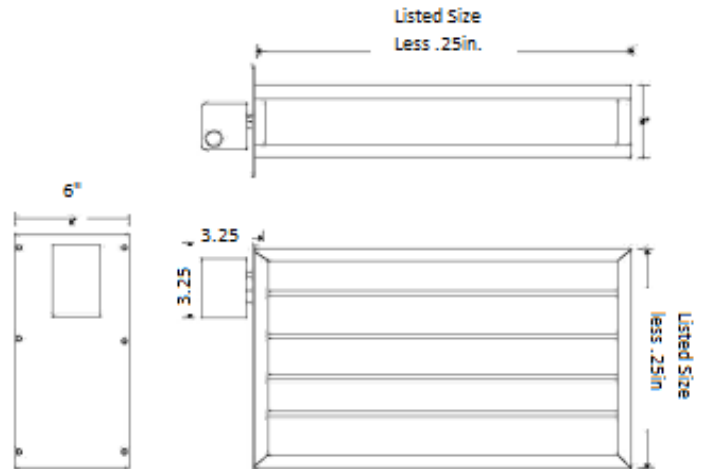

Damper Specifications

Construction – Aluminum Mill Finish, Mitre Angles

Linkage – Zinc plated linkage arm, Delrin bushings

Dimensions – 8"x 8" to 30"x 16" in 2" increments, 1/4" undersized*.

Motor Voltage – 24Volts AC, 50/60Hz, 6.5 Watts, 7VA

Torque – Power Start/Finish: 70 to 40 in-oz; Spring Start/Finish 60 to 30 in oz

Temperature Rating - 0°F to 150°F Operating, -20°F to 175°F Storage

Humidity – 5% to 95% Non-Condensing

Damper Timing – Nominal 30 Sec. Powered, 20 Sec. Spring Return

Connection: 4" Wire Leads

Static Pressure – Maximum 1.0 "W.C.

*Contact factory for sizes above 30" x 16".

INSTALLATION

1. Cut a 4-inch (102-millimeter) opening in one side of the air duct at the location selected. Ensure the opening is cut fully to the top and bottom air duct seams.
2. Slide the damper into the cut opening of the air duct. Ensure the electric actuator is mounted toward the top of the air duct.
3. Secure the damper mounting plate to the air duct with the sheet metal zip screws provided.

Side Mount:

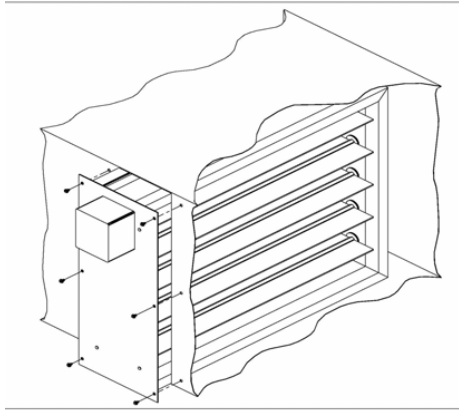

Bottom Mount:

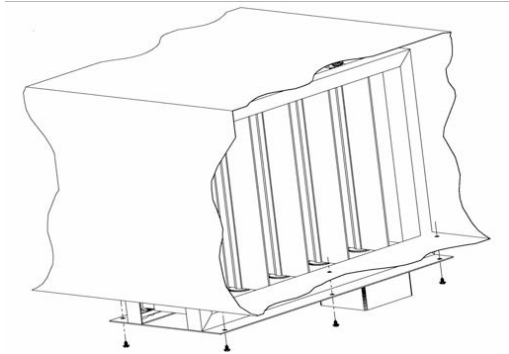

Wiring Diagrams

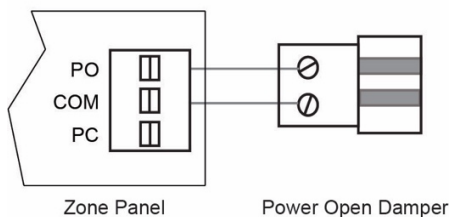
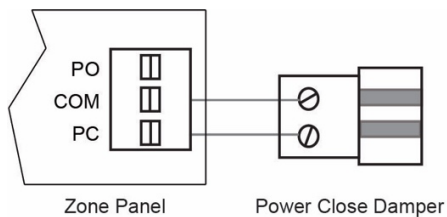

Converting from Power Close to Power Open

Tools Required:

Flat Head (3/16x7") screwdriver (magnetized tip if available, if not available then will need 1" of any type of adhesive tape)

1. Place the damper on a flat surface, position the damper with the motor towards the top and to the right.
2. Remove the motor and the motor couplings using the flat head screwdriver. Between the faceplate and the damper frame you will find the slotted set screw. Loosen and remove the set screw and the motor will slide off the damper blade shaft.
3. Position the damper so that you can see the damper blade linkage assembly (crankarms & drawbar), on opposite end of the damper motor. Note the position of the linkage assembly (crankarms @ approximately 1 o'clock position & draw bar to the right of the crankarms).
4. Remove linkage assembly by gently prying (use flat head screwdriver) up on the base of the crankarm. The crankarm is attached to the damper blade busing via a snap fitting. Disengage all of the crankarms from the blade bushings. DO NOT REMOVE THE DRAW BAR FROM THE CRANKARMS.
5. Rotate all off blades counter clockwise (CCW) all the way to the CLOSED position.
6. Reattach/ reposition the linkage assembly with the crankarms now positioned @ the 7 o'clock position and the draw bar positioned to the left of the crank arms. Once the linkage assembly is securely repositioned, manually rotate the blades open & close to ensure blades move smoothly. Position the blades CLOSED.
7. Reattach the motor. Ensure the damper blades are in tightly close position. Slide the motor and the motor couplings back on to the blade shaft. Reinsert the set screw (many need to tape set screw to screwdriver for insertion into coupling) and tighten securely.
8. Apply power to motor to ensure damper powers open & springs closed.

Power Open

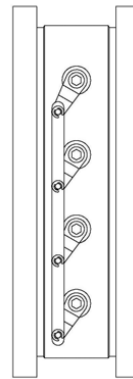

Power Closed

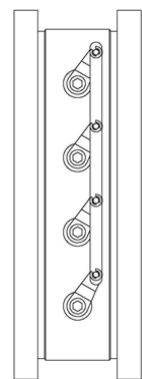

POWER OPEN Crank arms shown in Closed Position
POWER CLOSED Crank arms shown in Open Position