

Premier Series Programmable Thermostats

MODEL **5000** Single Stage Heat / Cool
7 Day or 5 - 2 Day Programmable

**Before Installing, Programming or Operating,
PLEASE READ ALL INSTRUCTIONS**

- 1 Specifications
- 2 Installation
- 3 Testing Your New Thermostat
- 4 Programming User Settings
- 5 Setting Your Energy Saving Program
- 6 Temperature Adjustment
- 7 Additional Operation Features
- 8 Battery Replacement
- 9 Troubleshooting
- 10 Wiring Diagrams

WARNING

Important Safety Information

- Always turn off power to the air conditioning or heating system prior to installing, removing, cleaning or servicing thermostat.
- This thermostat requires either 24 Volts AC Power or two (2) properly installed "AA" alkaline batteries for normal operation and control of the heating or cooling system.
- This thermostat requires two (2) properly installed "AA" alkaline batteries to retain clock setting in the event of loss of AC Power due to a power outage or rolling blackouts when used as a hardwired thermostat.
- This thermostat should only be used as described in this manual. Any other use is not recommended and will void the warranty.

1 Specifications

- Electrical Rating: 24 Volt AC (18-30 Volt AC)
1 amp maximum load per terminal
3 amp total maximum load (all terminals)
- Control Range: 45° - 90° F (7° - 32° C)
- Accuracy: +/- 1° F (+/- .5° C)
- AC Power: 18-30 Volt AC
- DC Power: 3.0 Volt DC (2 AA Alkaline batteries included)

1 Specifications *cont.*

- Compatibility: Compatible with low voltage single stage gas, oil or electric heating or cooling systems, including single stage heat pumps. This thermostat can also be used on 250mv to 750mv millivolt heating only systems.
- Terminations: Rc, Rh, B, O, Y, W, G, C

2 Installation

Replacing Existing Thermostat

Most thermostats have three parts:

- The cover, which may snap or hinge over the existing thermostat.
 - The electronics or body, which controls the existing system.
 - The sub-base, where the wires attach through the wall to the existing system.
1. Always turn off power to the air conditioning and heating system prior to removing existing thermostat.
 2. Carefully remove the cover and electronics body from the old thermostat sub-base. Depending on the brand, these parts may pull off or need to be unscrewed. The old sub-base should remain wired and on the wall until steps 4 and 5.
 3. Label every old wire with the letter of the connection to which the wire is attached. Example letters are R, M, and Y etc. Depending on the brand of the old thermostat, your letters may be different.
 4. After labeling the old wires, loosen each connection and remove them from old sub-base. Secure the wires to prevent them from slipping into the hole in the wall.
 5. Remove the old sub-base from the wall, again being careful that the wires do not slip into the hole in the wall.
 6. Use the chart below to determine the new thermostat connections. As an example, if the old thermostat had a G or F connection, it goes to G on the new thermostat. Using a pencil and the chart below, circle the letter of each wire removed from the old thermostat.

Old Terminal from Existing Thermostat	New Terminal for New Thermostat	Terminal Description
V or RC	Rc	Cooling Transformer
M, 4, Rh or R	Rh	Heating Transformer
B	B	Reversing Valve (Heating)
O	O	Reversing Valve (Cooling)
Y	Y	Cooling Control
H, W or 4	W	Heating Control
G or F	G	Fan Control
C	C	24 Volt AC, Transformer Common

NOTE: This thermostat is designed for use with 24 Volt AC low voltage single stage gas, oil or electric heating or cooling systems, including single stage heat pumps. This thermostat can also be used on 250mv to 750mv millivolt heating only systems. Do not use this thermostat on applications with voltages above 30 Volts AC.

Installing Your New Thermostat

NOTE: When installing this thermostat in a new location, following a few simple guidelines and the applicable building codes will give the best results. Install the thermostat in a location that provides good airflow by avoiding areas behind doors, near corners, air vents, direct sunlight or heat generating devices. The wiring must conform to all building codes and ordinances as required by local and national code authorities having jurisdiction for this installation.

1. Always turn off the power to the air conditioning and heating system prior to installing this thermostat.
2. Locate the release latch on the bottom (not the back) of the thermostat. Press the release latch in and separate the body from the sub-base of the thermostat.
3. Set the thermostat electronics and cover down on a clean surface. Place the sub-base on the wall in the desired location.
4. Using the slotted mounting holes in the sub-base, mark the placement of the mounting holes through the slots and onto the wall. Insure the wires come out of the wall into the center hole of the sub-base.
5. After verifying the drill will not damage items in the wall, use a 3/16 drill to create the mounting holes. Gently tap the supplied plastic anchors into the holes in the wall.
6. Place the thermostat sub-base against the wall in the desired location. Ensure the thermostat is level, the wires are inserted in the opening, and the mounting holes are aligned with the slots on the sub-base.
7. Fasten sub-base to wall using the supplied screws into the plastic wall anchors.
8. Connect wires to the quick wiring terminal blocks. Use the wiring diagram chart to insure the old and new connections are correct.
9. To prevent electrical shorts and potential damage to the thermostat, make sure all wire connections are secure and not touching each other.
10. Turn the thermostat body over, exposing the rear view of the circuit board.
11. Locate the internal °F / °C switch on the circuit board. Using your fingers, flip the switch toward the preferred temperature °F / °C scale.
12. Locate the internal fan option switch, **HG** (Gas) / **HE** (Elec) on the circuit board. This switch controls the heating system fan delay. Select gas for gas or oil fired systems. This will allow the furnace to run for a few seconds before starting the fan. Select electric for systems with electric furnace elements that require the fan to come on immediately. Using your finger, flip the switch toward the **HG** (Gas) or **HE** (Elec).
13. Locate the internal **NORM HP** switch on the circuit board. This switch configures the thermostat for normal (NORM) heating and cooling systems or heat pump (HP) systems. Using your fingers, flip the switch toward the **NORM** or **HP**.
14. Locate the internal programming switch on the circuit board. This switch configures the programming mode for either **5-2 DAY** (weekday-weekend), or full **7 DAY** programming. Using your finger, gently flip the switch toward the programming option that best suits your schedule.
15. Ensure the cover is still installed on the thermostat body, and install the unit onto the sub-base. To do so, use the mounting tabs on the top of the sub-base as a guide hinge, and close up the thermostat case by pivoting the body and cover closed. The latch on the bottom of the thermostat will click when the case is properly closed.
16. Flip the front thermostat cover open and open the battery compartment door.

(continued on page 3)

(continued from page 2)

17. Locate the positive [+] ends of the batteries and match them with the positive [+] terminals located in the battery compartment. Install the two new "AA" alkaline batteries (supplied). Close battery compartment door.
18. Restore system power and proceed to Testing Your New Thermostat.

NOTE: If batteries were installed prior to accomplishing steps 10 through 15, you will need to reset the thermostat to register thermostat switch configurations prior to programming any user settings. Gently press the **RESET** button on the front of the thermostat using a paper clip or a small pencil tip.

3 Testing Your New Thermostat

WARNING! Read *BEFORE* Testing

- Do not short (or jumper) across terminals on the gas valve or at the heating or cooling system control board to test the thermostat installation. This could damage the thermostat and void the warranty.
- Do not select COOL mode of operation if the outside temperature is below 50° F (10° C). This could possibly damage the controlled cooling system and may cause personal injury.
- This thermostat includes an automatic compressor protection feature to avoid potential damage to the cooling system from short cycling. This thermostat automatically provides a 5-minute delay after turning off the cooling system output to protect the compressor. This protection is also present in the heat mode of operation on single stage heat pump systems.

NOTE: Test your thermostat prior to programming any user settings. Pressing the **RESET** button will erase any user entries previously programmed and return them to their default values.

1. Place the system switch in the **HEAT** position.
2. Press the **A** button on the keypad until the set point temperature setting is a minimum of 3 degrees higher than the current room temperature. The heating system should start within several seconds. The fan may not turn on immediately due to the heating system built-in fan delay.
3. Place the system switch in the **OFF** position. The heating system should stop within several seconds on normal single stage heating or cooling systems. On single stage heat pump systems you must wait 5 minutes for the automatic compressor short cycle protection period to expire, or press the **RESET** button to bypass this feature for initial testing purposes. Pressing the **RESET** button will erase any user entries for time of day, day of week, option settings and programming if previously programmed.
4. Place the system switch in the **COOL** position.
5. Press the **V** button on the keypad until the set point temperature is a minimum of 3 degrees lower than the current room temperature.
6. The cooling system should start within several seconds. Place the system switch in the **OFF** position. The cooling system should stop within a few seconds.
7. Place the fan switch in the **ON** position. The system blower should start.
8. Place the fan switch in the **AUTO** position. The system blower should stop.

4 Programming User Settings

Default Thermostat Settings

Function	Status After Reset
Operation Mode	Normal Operating Mode
Temperature Hold	Extended and Temporary Hold Cleared
Clock	12:00 p.m., Monday
Room Temperature	70° F (21.0° C), to be renewed within 5 seconds
Set Point Temperature	According to System Switch 62° F (17.0° C) for Heat and Off 83° F (28.0° C) for Cool
Temperature Scale	°F or °C dependent on switch setting
Operating Program	DAY program, Monday
Low Battery Warning	Off, to be renewed within 5 seconds
Temperature Differential	0.5° F (0.25° C)
Short Cycle Protection Timer	Reset
Output Relays	Off
Extended Hold	Indefinite
Keypad Lock	Unlocked
Adaptive Recovery Mode	Off
Residual Cooling Fan Delay	60 seconds
Filter Check Monitor	0 days-off

Setting Current Time of Day and Day of Week

NOTE: It is important for you to set the current time of day (note AM/PM indicator in display), and the current day of week correctly to avoid problems with program execution.

1. When in normal operating mode, press the **DAY/TIME** keypad button. The LCD display will be cleared except for the time, am/pm indicator and the day of the week. The hour portion of the time will flash.
2. Press the **▲** or **▼** button to set current hour.
3. Press the **DAY/TIME** button again, the minute portion of the time will flash.
4. Press the **▲** or **▼** button to set the current minute.
5. Press the **DAY/TIME** button again. The day of the week indicator will flash.
6. Press the **▲** or **▼** button to set the current day of the week.
7. Press the **DAY/TIME** button again and the thermostat will return to normal operating mode.

NOTE: The thermostat will return to normal operating mode automatically after 30 seconds if no key is pressed. It will also return to normal operating mode immediately if the **RETURN** button is pressed.

4 Programming User Settings *cont.*

Setting Thermostat User Options

The default user options are compatible with most systems and applications. They are normally set at the time of installation and usually do not require modification under normal operating conditions. If you wish to change these settings, simply follow the instructions below.

NOTE: The temperature differential settings are the same for both the heating and cooling systems.

Setting the Temperature Differential

The default setting is 0.5° F (0.25° C). The room temperature must change 0.5° F (0.25° C) from the set point temperature before the thermostat will call for heating or cooling.



1. In normal operating mode, press and hold the **RETURN** button for 4 seconds. The LCD display will show "d1 X", where "X" equals the °F / °C differential setting. This is the current temperature differential setting.
2. Press the **▲** or **▼** button to set the temperature differential to your desired setting of 0.5°, 1°, or 2° F (0.3°, 0.5°, or 1° C).

NOTE: Once you have finished setting the temperature differential you can wait 30 seconds and the thermostat will automatically return to the normal operation mode. Otherwise, you can press the **RETURN** button again to set the Residual Cooling Fan Delay. When you go directly to the next programming step, it is not necessary to press and hold **RETURN** for 4 seconds.

Setting Residual Cooling Fan Delay

The default setting is 60 seconds. During the **COOL** mode of operation, the fan will stay on for 60 seconds after the set point temperature has been satisfied, and the compressor has shut off.



1. In normal operating mode, press and hold the **RETURN** button for 4 seconds. Press **RETURN** again until "FAN XX" is displayed where "XX" is the fan delay time in seconds.
2. Press the **▲** or **▼** button to change the Residual Cooling Fan Delay to the desired setting of 0 (disabled), 30, 60, or 90 seconds.
3. Press the **RETURN** button again to set the Extended Hold Time or wait 30 seconds for the thermostat to return to the normal mode.

Setting the Extended Hold Time (see section 7)

The default setting is Long (indefinite) Hold. If the HOLD feature is activated, the current set point will be held until HOLD is released.

1. In normal operating mode, press and hold the **RETURN** button for 4 seconds. Press **RETURN** repeatedly until "HOLD LG" is displayed where "LG" is indefinite hold. (continued on page 6)

4 Programming User Settings *cont.*

Setting the Extended Hold Time (continued)

- Press the **▲** or **▼** button to change the Extended Hold time from indefinite (**LG**) to 24 hours (**SH**).
- Press the **RETURN** button again to set the Filter Check Monitor or wait 30 seconds for the thermostat to return to the normal mode.

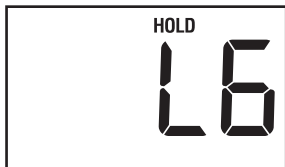

Setting Filter Check Monitor (see section 7)

The default setting is 0 days (Filter Monitor disabled).

- In normal operating mode, press and hold the **RETURN** button for 4 seconds. Press **RETURN** repeatedly until "**XXX FLT SET**" is displayed where "**XXX**" is the Filter Monitor interval (number of days since last warning).
- Press the **▲** or **▼** button to change the Filter Monitor interval to the desired value of 0 (disabled), 30, 60, 90, 120, or 180 days. Press the **RETURN** button again to set adaptive recovery mode or wait 30 seconds for the thermostat to return to normal mode.



Setting Adaptive Recovery Mode (**ARM™**) (see section 7)

The default setting is OFF (Adaptive Recovery Mode disabled).

- In normal operating mode, press and hold the **RETURN** button for 4 seconds. Press **RETURN** repeatedly until "**REC XX SE**" is displayed where **XX** is the Adaptive Recovery Mode status.
- Press the **▲** or **▼** button to change the Adaptive Recovery Mode to either **ON** or **OFF**.
- Press the **RETURN** button again or wait 30 seconds for the thermostat to return to the normal mode.



5 Setting Your Energy Saving Program

Setting Your Energy Saving Program—Tips Before Starting

- It is important for you to set the current time of day (note the AM/PM indicator in the display), and the current day of week correctly to avoid problems with program execution. This must be done prior to entering any program settings.
- The heating and cooling programs have both separate set point times and set point temperatures.
- This thermostat is preprogrammed with weekday and weekend set point times and temperatures. These settings provide efficient energy savings during normal heating and cooling modes of operation. If you wish to use the settings in the table, no further programming is necessary. Review these time and temperature settings prior to establishing your personal program settings to maximize your savings, and minimize programming requirements.

	Weekday	Weekend
MORN	Time: 6:00 am	Time: 6:00 am
	Heat: 70° F (21° C) Cool: 75° F (24° C)	Heat: 70° F (21° C) Cool: 75° F (24° C)
DAY	Time: 8:00 am	Time: 8:00 am
	Heat: 62° F (17° C) Cool: 83° F (28° C)	Heat: 70° F (21° C) Cool: 75° F (24° C)
EVE	Time: 6:00 pm	Time: 6:00 pm
	Heat: 70° F (21° C) Cool: 75° F (24° C)	Heat: 70° F (21° C) Cool: 75° F (24° C)
NIGHT	Time: 10:00 pm	Time: 10:00 pm
	Heat: 62° F (17° C) Cool: 78° F (26° C)	Heat: 62° F (17° C) Cool: 78° F (26° C)

- Make sure you place the system switch in the **HEAT** or **COOL** modes of operation as appropriate. You should not enter a program in the **OFF** position.
- When the system switch is in the **COOL** or **HEAT** modes of operation, the appropriate indicator will appear in the LCD display when the system is running. When the system switch is in the **OFF** mode the display will indicate **OFF**.

NOTE: For 7 day programming the defaults follow the Weekday programming shown above. To change between 5-2 and 7 day programming, adjust switch by following step 14 of Installation section.

Entering Your Program – 5-2 Day Mode

The 5-2 Day mode has separate Weekday and Weekend Program Groups that allow you to change the daily set point times and temperatures to meet your individual schedule needs.

Weekday - allows you to program all the weekdays (M, TU, W, TH, F will show in display) at the same time. Allows programming times and temperature settings for four set points (MORN, DAY, EVE and NIGHT) to meet your weekday schedule needs.

Weekend - allows you to program all the weekend days (SA, SU will show in the display) at the same time. Again allows programming times and temperature settings for four set points (MORN, DAY, EVE and NIGHT) to meet your weekend schedule needs. *(continued on page 8)*

1. Place the system switch in the **HEAT** mode of operation.
2. Press the **PROG** button to enter the Program setting mode. **MORN** set point of the Weekday Program Group will be displayed. The display will show **M, TU, W, TH, F** to indicate the Weekday group is being programmed. The hour and the AM/PM indicator will be flashing.



3. Press the **▲** or **▼** button to change the time to the desired hour in one hour increments. Press the **PROG** button. The minute portion of the set point time will begin flashing.
4. Press the **▲** or **▼** button to change the time to the desired minute in 10-minute increments. Press the **PROG** button. The SET temperature will begin flashing.
5. Press the **▲** or **▼** button to change the set point temperature to the desired setting in 1° (.05° C) increments. Press the **PROG** button. The thermostat will now display the **DAY** set point time and temperature. Again, you will see the hour and the **AM/PM** indicator flashing.
6. Follow steps 3 through 5 to set the set point times and temperatures for the periods of **DAY, EVE** and **NIGHT**.
7. After pressing the **PROG** button, you will enter the Weekend Program Group. The display will show **SA, TU, SU** to indicate the Weekend Group is being programmed. The hour portion of the **MORN** set point time and the **AM/PM** indicator will be flashing.
8. Follow steps 3 through 6 to set the set point time and temperatures for the periods of **MORN, DAY, EVE** and **NIGHT**.
9. Place the system switch in the **COOL** mode of operation. The display will show **COOL**. Follow steps 2 through 8 to program the set point times and temperatures for the Weekday and Weekend groups in the **COOL** mode.

NOTE: To erase all entered programs, current time of day, day of week and other user settings, gently press the **RESET** button using a paper clip or a small pencil tip. This will return all thermostat settings to their default values.

Entering Your Program – 7 Day Mode

The 7 Day mode has separate Whole Week or Individual Day programming to allow you to change the daily set point times and temperatures to meet your individual schedule needs. The Whole Week programming can be used to set the main portion of your schedule, allowing you to later modify specific days of the week as required using the Individual Day programming capabilities.

Whole Week - allows you to program all seven days (M, TU, W, TH, F, SA, SU will show in display) at the same time. Then you can use the individual day programming to fine tune your program for the few set point times or temperatures that you may wish to change.

Individual Days - allows you to program each day of the week individually to give you the greatest schedule flexibility. Often used to fine tune programming after initial programming. (continued on page 9)

Entering Your Program – 7 Day Mode (continued from page 8)

IMPORTANT NOTE! When in Whole Week programming, the thermostat will check if all of the days of that group have the same program set point times and temperatures. If so, the set point time and temperature of the individual set point will be displayed. Otherwise, the individual set point time and temperature will be blanked. The user is allowed to change the daily programs for this set point time and temperature by pressing the **▲** or **▼** button. This will reset all the daily programs of the group for that specific individual set point time and temperature to the startup default for that set point. Continued pressing of the **▲** or **▼** button by the user will change set point time and temperature settings as desired.

1. Place the system switch in the **HEAT** mode of operation.
2. Press the **PROG** button to enter Program setting mode. The **MORN** set point of the Whole Week Program Group will be displayed. The display will show **M, TU, W, TH, F, SA, SU**, indicating the whole week is being programmed. The hour and the **AM/PM** indicator will be flashing.
3. If you wish to program each day individually press the **DAY/TIME** button to select a specific day.
4. Press the **▲** or **▼** button to change the time to the desired hour in one hour increments. Press the **PROG** button. The minute portion of the set point time will begin flashing.
5. Press the **▲** or **▼** button to change the time to the desired minute in 10-minute increments. Press the **PROG** button. The SET temperature will begin flashing.
6. Press the **▲** or **▼** button to change the set point temperature to the desired setting in 1° (.05° C) increments. Press the **PROG** button. The thermostat will now display the **DAY** set point time and temperature. Again, you will see the hour and the **AM/PM** indicator flashing.
7. Follow steps 4 through 6 to set the set point times and temperatures for the periods of **DAY, EVE**, and **NIGHT**.
8. Place the system switch in the **COOL** mode of operation. The display will show **COOL**. Follow steps 2 through 7 to program the set point times and temperatures for the **COOL** mode.

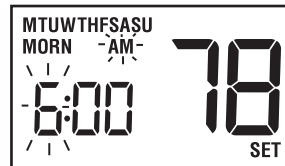

NOTE: To erase all entered programs, current time of day, day of week and other user settings, gently press the **RESET** button using a paper clip or a small pencil tip. This will return all thermostat settings to their default values.

6 Temperature Adjustment

Review Set Temperature

1. Press and hold the **▲** or **▼** button. The current set point temperature will be displayed in place of the current room temperature, and the indicator **SET** will be displayed.
2. The display will return to normal operating mode when the **▲** or **▼** button is released. Continuing to hold the **▲** or **▼** button for 1 second or longer will allow the user to temporarily override the current programmed set point.

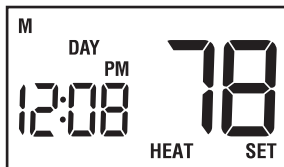

Temporary Program Override

1. Press and hold **▲** or **▼** button for 1 second or longer. The entire display will flash once and the **SET** indicator will be displayed. Release the **▲** or **▼** button and press the **▲** or **▼** button again as desired to adjust the set temperature.
2. The display will return to normal operating mode after 15 seconds or you can press the **RETURN** button.
3. The program indicator (**MORN**, **DAY**, **EVE** or **NIGHT**) will be flashing in the display, indicating that a Temporary Program Override is in effect. The Temporary Program Override will reset when the next set point time occurs or after four hours—whichever comes first.

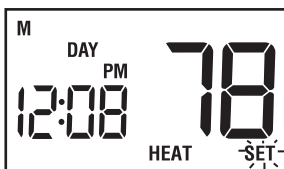

Extended Hold (Vacation) Mode

1. Press the **HOLD** button to bypass the program schedule. The current set point temperature will be held either permanently or for 24 hours, depending on the setting selection made in section 4.
2. Press the **HOLD** button again to return the thermostat to the normal program operation.
3. The hold period will last until the hold is released as in step number 2 above, or is limited to 24 hours if the default was changed in the User Options Settings (see section 4).

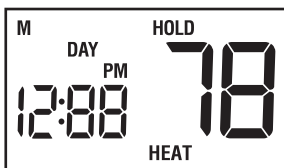

7 Additional Operation Features

Filter Check Monitor (see section 4)

The Filter Check Monitor displays a reminder for required filter replacement or cleaning by flashing the **FILT** segment in the display. See instructions on your filter or heating/cooling unit for recommendations for interval setting. When the selected interval has been reached, and required cleaning or replacement has been performed, press the **RETURN** button in any normal mode to reset the timer and turn off the warning.

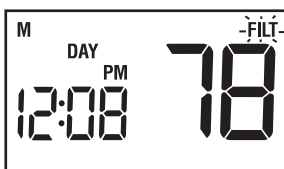

7 Additional Operation Features *cont.*

Locking the Keypad

To prevent accidental or undesired adjustment of the thermostat, the Keypad Lockout feature disables the operation of the keypad except for the backlight key. In order to lock the keypad, press and hold both the **▲** and **▼** buttons together at the same time for 5 seconds. The **LOCK** segment in the display will flash once per second, and then appear continuously in the display. The keypad is now locked. To unlock the keypad, press and hold the **▲** and **▼** buttons together at the same time for 1 second. The **LOCK** segment will disappear and the keypad will become unlocked.

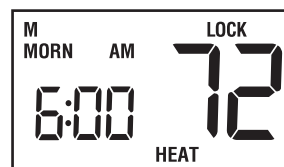

Adaptive Recovery Mode (ARM™) (see section 4)

In order to maximize comfort and energy efficiency, this thermostat is equipped with an Adaptive Recovery Mode (ARM™). This feature minimizes the amount of time required by heating or cooling system to reach the new set point, after a setback period is completed, and assures your desired temperature is achieved at your set program times.

This feature activates when recovering room temperature from setback programs to comfort programs, so it will only take place when the current (heating) program set point temperature is lower than the upcoming program set point temperature, or the current (cooling) program set point temperature is higher than the upcoming program set point temperature.

During ARM™, room temperature is recovered gradually by turning on the heating or cooling before the end of the setback period. The set point temperature is changed to that of the upcoming comfort program temperature. The start time of recovery is based on the difference between the current room temperature and the upcoming comfort program set point temperature. The recovery to the upcoming set point starts 10 to 15 minutes before the upcoming set point time for each degree of temperature change required, up to a maximum of 2 hours in the HEAT mode, 3 hours in the COOL mode.

ARM™ does not operate when the unit is in HOLD mode, or if the program is temporarily overridden.

Circulating Fan Mode—Fan Operation

AUTO: Fan operates as required by heating or cooling system.

⌚: When heating or cooling is not active, fan will run as needed to ensure a 35% minimum run time.

ON: Fan will run at all times.

7 Additional Operation Features *cont.*

Compressor Protection

This thermostat includes an automatic compressor protection feature to avoid potential damage to the cooling system from short cycling. This thermostat automatically provides a 5-minute delay after turning off the cooling system output to protect the compressor. This protection is also present in the heat mode of operation on single stage heat pump systems to protect the compressor.

NOTE: The installer can reset the thermostat and bypass the compressor protection features by pressing the **RESET** button. This will erase all entered programs, current time of day, day of week and other user settings and should only be used during installation for testing purposes or to reset a thermostat to regain normal operation. This will return all thermostat settings to their default values.

Low Battery Detection

This thermostat requires two (2) new, properly installed "AA" Alkaline batteries to maintain the system clock and to provide proper thermostat power when 24 volt AC power fails or is not connected to the thermostat. When the batteries start to become too weak to provide proper operation, the thermostat will begin to display a low battery indicator.



The low battery indicator is provided to inform the user when the batteries require immediate attention. We recommend replacing the batteries as soon as the low battery indicator appears. If the batteries are not replaced after the low battery indicator first appears, the thermostat may not provide proper heating or cooling system operation.

Even if the low battery indicator does not appear, the batteries should be replaced at least once a year, or if you plan on leaving the premises for over a month.

This thermostat can be powered from 24 volts AC or battery power. To determine if 24 volt AC power is connected to the thermostat, refer to the installation and wiring diagram section. If you cannot determine how this thermostat is powered, call a professional service technician to determine the type of installation and the proper operation of your system.

7 Additional Operation Features *cont.*

Resetting the Thermostat

The Reset feature allows the user to completely reset the thermostat to register new manual switch settings. To erase all entered programs, current time of day, day of week and other user settings, gently press the **RESET** button using a paper clip or a small pencil tip. This will return all thermostat settings to their default values and register all new manual switch settings for proper operation.

Non-Volatile Memory

In the event of a power failure, the Non-Volatile Memory feature allows all settings to be recovered, eliminating the need to reset temperature and differential settings. When AC power is restored after an outage, all settings are retrieved from memory and reinstated.

Status Indicators

HEAT: This will turn on whenever the system switch is in the HEAT mode. "HEAT" will flash when the heating system is running.

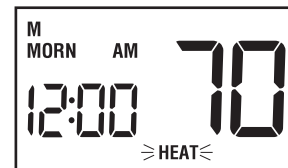

COOL: This will turn on whenever the system switch is in the cool mode. "COOL" will flash when the cooling system is running.



8 Battery Replacement

Replacing the Batteries

1. Open the thermostat cover and locate the battery compartment door.
2. Remove the two "AA" alkaline batteries located in the battery compartment.
3. Install two new "AA" alkaline batteries into battery compartment. Make sure to match the positive (+) ends of the batteries with the positive (+) terminals located in the battery compartment.
4. Close battery compartment and verify that the low battery indicator does not appear in the display.

9 Troubleshooting

Symptom: The word **HEAT** or **COOL** is flashing in the thermostat display.

Potential Solution: This indicates that the heating or cooling system is currently running. When these systems are not running, **HEAT** or **COOL** will not flash.

Symptom: **HEAT** or **COOL** is flashing but the system is not running.

Potential Solution: The thermostat is telling the heating or cooling system to run, but the system is not responding. You may need to call your local heating and air conditioning contractor.

Symptom: Thermostat does not turn on heating or cooling system.

Potential Solutions: Check to see if **OFF** is shown in display. This indicates that the system is turned off at the thermostat. Move the system selector switch to the **HEAT** or **COOL** position. After the compressor short cycle protection 5-minute period expires the system should start.

Compressor protection feature may be in effect due to compressor short cycle conditions. See section 7.

Heating or cooling system may be malfunctioning.

Call a professional service technician immediately to verify system operation.

Symptom: Thermostat turns on heating instead of cooling or cooling instead of heating.

Potential Solution: Check thermostat wiring to make sure that the heating and cooling stages are connected to the correct terminals on the wiring terminal block. See section 10.

Symptom: Thermostat will not follow program set points.

Potential Solutions: Check current time of day, day of week program settings. Make sure to verify **AM/PM** indicator is accurately displaying desired time settings. See section 5.

Check to see if **OFF** is shown in display. This indicates that the system is turned off at the thermostat. Move the system selector switch to the **HEAT** or **COOL** position. After the compressor short cycle protection period expires the system should start within several seconds.

Thermostat program is in Extended Hold (Vacation) Mode and **HOLD** is showing in display. Press **HOLD** or **RETURN** button to release permanent hold and return the thermostat to normal program operation.

Symptom: Thermostat turns heating or cooling system on too often or not often enough.

Potential Solution: Increase or decrease first stage temperature differential setting as appropriate to provide the desired performance level. See section 4.

Symptom: Low battery indicator is shown in thermostat display.

Potential Solution: Replace batteries immediately to maintain proper system operation. See section 8.

9 Troubleshooting *cont.*

Symptom: **HI** is shown in the thermostat display where the room temperature is normally displayed.

Potential Solutions: The temperature sensed by the thermostat is higher than the 99° F (37° C) upper limit of the thermostat's display range. The display will return to normal after the sensed temperature lowers within the 40° to 99° F (4° to 37° C) display range. Turn on the cooling system or use other methods to lower the temperature.

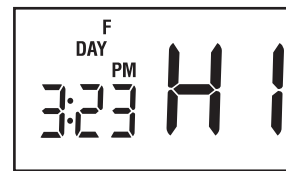

Symptom: **LO** is shown in the thermostat display where the room temperature is normally displayed.

Potential Solutions: The temperature sensed by the thermostat is lower than the 40° F (4° C) lower limit of the thermostat's display range. The display will return to normal after the sensed temperature rises within the 40° to 99° F (4° to 37° C) display range. Turn on the heating system to raise the temperature as needed for comfort within the room.

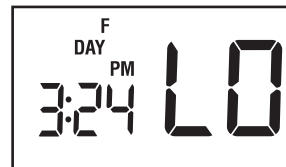

Symptom: Cannot program a set point temperature higher than 90° F (32° C).

Potential Solution: This is above the normal thermostat temperature setting range of 45° to 90° F (7° to 32° C).

Symptom: Cannot program a set point temperature lower than 45° F (7° C).

Potential Solution: This is below the normal thermostat temperature setting range of 45° to 90° F (7° to 32° C).

Symptom: Thermostat will not allow set point changes.

Potential Solution: The Keypad is locked. Press the **▲** and **▼** key together at the same time for one second to unlock. See section 7.

Symptom: Fan continues to run all the time whether the system is on or off.

Potential Solution: Check that the fan control switch is in the **AUTO** position. This will allow the fan to run only when the heating or cooling system is turned on and running.

Check thermostat wiring to make sure that the fan control wiring is connected to the correct terminals on the wiring terminal block. See section 10.

Symptom: Fan Runs intermittently or when system is OFF.

Potential Solution: Fan switch is in Circulate (Ⓒ) Mode. See section 4.

Symptom: The room is too warm or too cold.

Potential Solution: See section 4 of this manual to verify the current set point and make any modifications that are necessary.

Symptom: System turns on prior to the end of a setback period.

Potential Solution: Thermostat is in Adaptive Recovery Mode. See sections 4 and 7.

Single Stage Conventional Systems (Single Transformer)

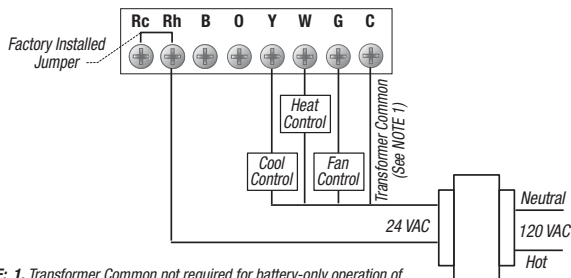

NOTE: 1. Transformer Common not required for battery-only operation of thermostat. **2.** For heating or cooling only system, ignore opposite connection. **3.** For 2-wire 24 Volt AC or 250mV - 750mV millivolt heating systems, ignore cooling connection and fan control.

Single Stage Conventional Systems (Dual Transformer)

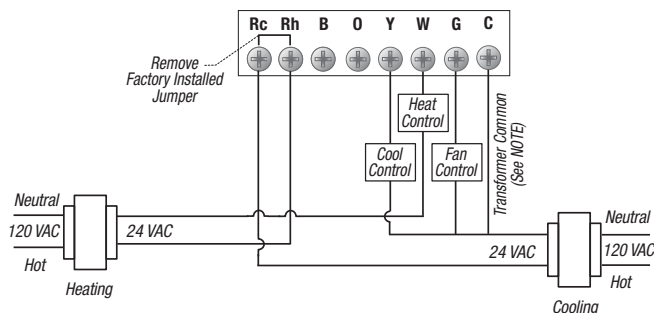

NOTE: Transformer Common not required for battery-only operation of thermostat.

Single Stage Heat Pump System

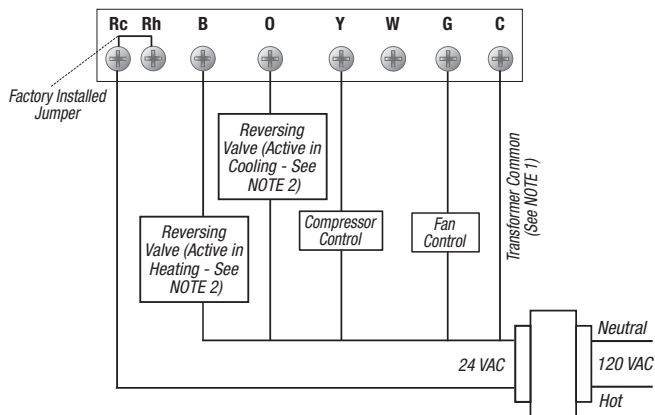

NOTE: 1. Transformer Common not required for battery-only operation of thermostat. **2.** For units requiring reversing valve to be energized during heating, connect reversing valve to B terminal. For units requiring reversing valve to be energized during cooling, connect reversing valve to O terminal.

Premier Series Programmable Thermostats

LIMITED WARRANTY

Braeburn Systems LLC warrants each new Braeburn thermostat against any defects that are due to faulty material or workmanship for a period of five years after the original date of purchase by a professional service technician. This warranty and our liability does not apply to batteries, nor does it include damage to merchandise or the thermostat resulting from accident, alteration, neglect, misuse, improper installation or any other failure to follow Braeburn installation and operating instructions.

Braeburn Systems LLC agrees to repair or replace at its option any Braeburn thermostat under warranty provided it is returned postage prepaid to our warranty facility in a padded carton within the warranty period, with proof of the original date of purchase and a brief description of the malfunction. This limited warranty does not include the cost of removal or re-installation.

This warranty gives you specific legal rights and you may also have other rights that vary from state to state or province to province. Answers to any questions regarding our limited warranty may be obtained by writing our corporate offices.

WARRANTY FACILITY: Braeburn Systems LLC
Attn: Warranty Department
2215 Cornell Avenue
Montgomery, IL 60538



Store this manual for future reference.

Braeburn®

Braeburn Systems LLC
2215 Cornell Avenue • Montgomery, IL 60538
Technical Assistance: www.braeburnonline.com
Call us toll-free: 866-268-5599 (U.S.)
630-844-1968 (Outside the U.S.)