

Premier Series Non-Programmable Thermostats

MODEL
3300 **Multi-Stage 3 Heat / 2 Cool**
Auto Changeover
Conventional and Heat Pump

**Before Installing or Operating,
PLEASE READ ALL INSTRUCTIONS**

- 1 Specifications**
- 2 Installation**
- 3 Quick Reference**
- 4 Programming
Installer Settings**
- 5 Programming
User Settings**
- 6 Additional Operation
Features**
- 7 Testing Thermostat**
- 8 Troubleshooting**
- 9 Wiring Diagrams**

WARNING

Important Safety Information

- Always turn off power to the air conditioning or heating system prior to installing, removing, cleaning or servicing thermostat.
- This thermostat is a dual power thermostat and either requires 24 Volt AC Power or two (2) properly installed "AA" Alkaline batteries for normal operation and control of the heating or cooling system.
- This thermostat should only be used as described in this manual. Any other use is not recommended and will void the warranty.

1 Specifications

- Electrical Rating: 24 Volt AC (18-30 Volt AC)
1 amp maximum load per terminal
5 amp maximum load (all terminals)
- Control Range: 45° - 90° F (7° C - 32° C)
- Accuracy: +/- 1° F (+/- .5° C), +/- 3% RH
- AC Power: 18-30 Volt AC
- DC Power: 3.0 Volt DC (2 "AA" Alkaline batteries included)
- Compatibility: Compatible with low voltage single stage or multi-stage heat / cool systems, including heat pumps with up to three stages of heating and two stages of cooling (three stage heating available on heat pump systems). This thermostat can also be used on 250 to 750 millivolt heating only systems.
- Terminations: G, Rc, Rh, W2, B, O, Y1, Y2, W1/E/W3, C, L, S1, S2

Replacing Existing Thermostat

Most existing thermostats have three parts:

- The cover, which may snap or hinge over the existing thermostat.
 - The electronics or body, which controls the existing system.
 - The sub-base, where the wires attach through the wall to the existing system.
1. Always turn off power to the air conditioning and heating system prior to removing existing thermostat.
 2. Carefully remove the cover and electronics body from the old thermostat sub-base. Depending on the brand, these parts may pull off or need to be unscrewed. The old sub-base should remain wired and on the wall until steps 4 and 5.
 3. Label every old wire with the letter of the connection to which the wire is attached. Example letters are R, M, Y, etc. Depending on the brand of the old thermostat, your letters may be different.

Old Terminal from Existing Thermostat	New Terminal for New Thermostat (Model 3300)	Terminal Description
G or F	G	Fan Control
Rc	Rc	24 Volt AC (Cooling for Dual Transformer Systems)
R, V-VR or VR-R	Rh	24 Volt AC
W1, W2 or W-U	W2	Stage 2 Heating
B	B	Reversing Valve (Heating)
O or R	O	Reversing Valve (Cooling)
Y, Y1 or M	Y1	Stage 1 Compressor
Y2	Y2	Stage 2 Compressor
W1/E/W3	W1/E/W3	1st Stage Heating for Conventional Systems or Emergency Heating for 3 Stage Heat Pumps
C, X or B	C	24 Volt AC, Transformer Common
L or X	L	System Malfunction Indicator
S1	S1	Optional Remote Sensor
S2	S2	Optional Remote Sensor

4. After labeling the old wires, loosen each connection and remove them from the old sub-base. Secure the wires to prevent them from slipping into the opening in the wall.
5. Remove the old sub-base from the wall, again being careful that the wires do not slip into the opening in the wall.
6. Use the chart on page 1 to determine the new thermostat connections. As an example, if the old thermostat had a G or F connection, it goes to G on the new thermostat. It may be helpful to use the chart by circling (with a pencil or pen) the letter of each wire removed from the old thermostat.

2 Installation *cont.*

NOTE: This thermostat is designed for use on low voltage 24 volt AC single stage or multi-stage systems, including heat pumps with up to three stages of heating and two stages of cooling (three stage heating available on heat pump systems). Do not use this thermostat on systems with voltage higher than 30 Volts AC. This thermostat requires a transformer common wire for proper installation if used as a hardwired thermostat.

Installing New Thermostat

NOTE: When installing this thermostat in a new location, following a few simple guidelines and the applicable building codes will give the best results. Install the thermostat in a location that provides good airflow by avoiding areas behind doors, near corners, air vents, direct sunlight or heat generating devices. The wiring must conform to all building codes and ordinances as required by local and national code authorities having jurisdiction for this installation.

1. Always turn off the power to the air conditioning and heating system prior to installing this thermostat.
2. Locate the release latch on the bottom (not the back) of the thermostat. Press the release latch in and separate the body from the sub-base of the thermostat. Because this thermostat has 13 possible connection points, you may need to apply moderate force to separate the parts.
3. Set the thermostat electronics and cover down on a clean surface. Place the sub-base on the wall in the desired location.
4. Using the slotted mounting holes in the sub-base, mark the placement of the mounting holes through the slots and onto the wall. Ensure the wires come out of the wall into the center hole of the sub-base.
5. After verifying the drill will not damage items in the wall, use a 3/16 drill to create the mounting holes. Gently tap the supplied plastic anchors into the holes in the wall.
6. Place the thermostat sub-base against the wall in the desired location. Ensure the thermostat is level, the wires are inserted in the opening, and the mounting holes are aligned with the slots on the sub-base.
7. Fasten sub-base to wall using supplied screws into the plastic wall anchors.
8. Connect wires to the quick wiring terminal blocks. Use the wiring diagram chart to ensure the old and new connections are correct.
9. To prevent electrical shorts and potential damage to the thermostat, make sure all wire connections are secure and not touching each other.
10. Locate the thermostat body, and ensure the cover is still installed properly. Using the mounting tabs on the top of the sub-base as a guide or hinge, close up the thermostat case by pivoting the body and cover closed. The latch on the bottom of the thermostat will click when the case is properly closed. Because this thermostat has 13 possible connection points, you may need to apply moderate force to close the case.
11. Flip the front thermostat cover up and open the battery compartment door.
12. Locate the positive [+] ends of the batteries and match them with the positive [+] terminals located in the battery compartment. Install the two new "AA" alkaline batteries (supplied). Close battery compartment door.
13. Restore system power and proceed to programming and system checkout.

3 Quick Reference

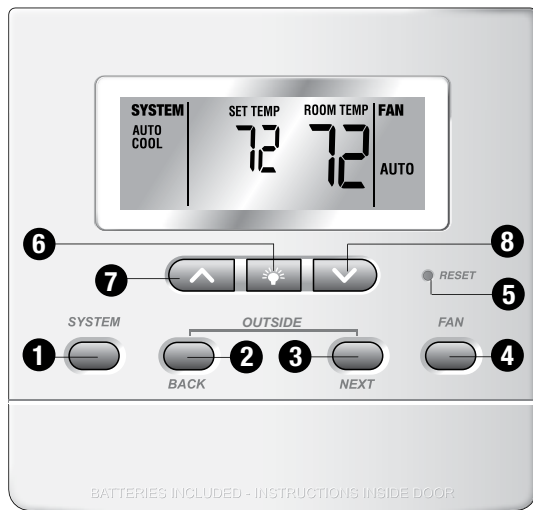

Model 3300 shown with cover open

- 1 SYSTEM Button:** Selects AUTO (Heat/Cool), COOL, OFF, HEAT or EMER.
 - 2 BACK Button:** Scrolls backwards between setup screens.
 - 3 NEXT Button:** Scrolls between setup screens. Press and hold for 3 seconds to enter the user settings mode.
 - 4 FAN Button:** Selects AUTO, ON or CIRC (recirculate) modes.
 - 5 RESET Button:** Located on front of thermostat. Resets a series of user options back to their factory default settings. See page 5 for a list of all functions that will return to their factory default settings after the RESET button is pressed.
 - 6 Button:** Turns on backlight for 10 seconds.
 - 7 Button:** Increases setting (temperature, etc.). Scrolls between option settings.
 - 8 Button:** Decreases setting (temperature, etc.). Scrolls between option settings.
 - 7 + 3 and NEXT Buttons:** Press at the same time for 3 seconds to enter Installer Settings Mode.
 - 2 + 3 BACK and NEXT Buttons (Installer Mode):** When pressed at the same time, returns unit to the Normal Mode from Installer Setup Option Mode.
 - 2 + 3 NEXT and BACK Buttons (Normal Mode):** When pressed at the same time, displays outside temperature if optional outside sensor is installed.
- CLEAR Button:** Located on the back side of the circuit board; resets thermostat to all factory default settings. See Page 4 for a complete listing.

4 Programming Installer Settings

Status After CLEAR—Factory Default Settings

At initial power up or after Installer **CLEAR** button is pressed, the thermostat is reset to factory defaults. Installer **CLEAR** button is located on the circuit board.

Function	Status After CLEAR
Operation mode	OFF, Auto Changeover enabled
Fan Switch	AUTO
Room temperature	Display 70° F (21.0° C), to be renewed within 5 seconds
Set point temperature	62° F (17.0° C) for Heat and Emergency Heat 83° F (28.0° C) for Cool
Temperature scale	Fahrenheit
Low-battery warning	Off, to be renewed within 5 seconds
AC interrupted warning	Off, to be renewed within 5 seconds
1st stage differential	0.2° F (0.1° C)
2nd stage differential	2° F (1.0° C)
3rd stage differential	2° F (1.0° C)
Deadband	3° F
Residual Cooling Fan Delay	60 seconds
Short cycle protection timer	On, 5 minutes, Reset
Output relays	All turned off
Recirculating Fan	Timer reset, with 24 min OFF, 12 min ON, Lock OFF
Keypad Lock	Complete (level 2), unlocked
System type	Conventional, Single Stage
1st Stage Heat Fan Control	Gas
2nd Stage Heat Fan Control	Electric
Fossil Fuel Compressor Lock	Off
Auto Changeover	Enabled
Compressor Outage Protection	Off, Timer reset
Temperature Sensor	Internal
Adjustment Limit from Set Point	0, OFF
AC Interrupt Warning Mode	OFF
Compressor Balance Point	NO – No Lockout
Auxiliary Balance Point	NO – No Lockout
Filter Check Monitor	0 days-No Warning, Timer reset
UV Monitor	0 days – No Warning, Timer reset
Humidifier Pad Monitor	0 days – No Warning, Timer reset
Heat Limit	90 deg – No Limit
Cool Limit	45 deg – No Limit

4 Programming Installer Settings *cont.*

Status After RESET—Factory Default Settings

When the User **RESET** button is pressed, the following options will reset to the factory defaults. All other settings are not changed when the **RESET** button is pressed.

Function	Status After RESET
Temperature	Heat - 62° F, Cool - 83° F.
1st stage differential	0.2° F (0.1° C)
2nd stage differential	2° F (1.0° C)
3rd stage differential	2° F (1.0° C)
Filter, UV and Humidity Pad Check Monitor	0 days-No Warning, Timer reset
Short Cycle Timer	Reset
Recirculating Fan	Timer reset, 24 minute off cycle. With recirculating lock set to ON (See Installer Settings), fan state defaults to CIRC.

Setting Thermostat Installer Options

The Installer Options section allows the system and programming parameters to be set up at installation. The Installer Options mode is menu driven. As the different options are programmed, unnecessary options will be eliminated. For example, if the system is set to single stage heat pump, Option 5, selecting the AUX stage fan control will no longer be available.

The Installer Option mode is entered by holding the **NEXT** and **▲** buttons together for 3 seconds. Installer Option 1 (Temperature Scale) will be displayed. Pressing the **▲** or **▼** buttons will scroll between choices. To scroll to the next installer option, press the **NEXT** button. To scroll backwards between installer options, press the **BACK** button. The thermostat will return to normal operating mode by pressing the **NEXT** and **BACK** buttons at the same time.

NOTE: The thermostat will return to normal operating mode automatically after 30 seconds if no buttons are pressed.

NOTE: Any changes to Installer Option 3 (System Type) will cause Options 4, 5 and 6 to reset to the default values that are dependent on system selection.

4 Programming Installer Settings *cont.*

Press the **NEXT** and **▲** buttons at the same time to enter Installer Mode.

Installer Options	Factory Default	Options	Comment
1 Temperature Scale	066F	066F, 066C	Selects either Fahrenheit or Celsius.
2 Auto Changeover	AUte00n	AUte00n, AUte00FF	Either enables or disables Auto Changeover.
3 System Type	11C	11C, 22C, 11HP, 22HP, 32HP	Selects single stage conventional, 2 stage conventional, single stage heat pump, 2 stage heat pump or 3 stage heat pump.
4 First Stage Fan Control	1H5	1H5, 1HE	Not available with a heat pump system. Selects between 1st stage gas or electric heat.
5 Aux Stage Control	2HE	2HE, 1H5	Only available with multi-stage heat pump system. Selects multi-stage gas or electric heat.
6 Fossil Fuel Backup Option	AUXAE	AUXAE, AUXAB	Only available with a multi-stage heat pump system. Locks out 1st stage during 2nd stage heat call for fossil fuel backup system (AUXAG). With an electric backup system (AUXAE), both stages will run.
7 AC Power Interrupt Warning	0FF-AC	0FF-AC, 0N-AC	Only available when thermostat is installed as a hardwired unit. Select between turning the AC power interrupt warning off or on.
8 Compressor Power Outage	CP0P 0F	CP0P0F, CP0P0n	Only available with multi-stage heat pump and AC power connected. Select between compressor lock off and compressor lock on.
9 Short Cycle Protection	CSCP 5	CSCP 5, CSCP 4, CSCP 3, CSCP 2, CSCP 0	Selects 5, 4, 3, 2 or 0 minutes for compressor short cycle protection.
10 Residual Cooling Fan Delay	FAN 60	FAN 00, FAN 30, FAN 60, FAN 90	Selects 0, 30, 60 or 90 seconds as the time the fan will stay on after the cooling system has satisfied the set point temperature and turned off the compressor.
11 Recirculating Fan Lock	CIRC0F	CIRC0F, CIRC0n	Selects between Recirculating Fan Lock off or on.
12 Set Sensor Control	SENS 1	SENS1, SENSE, SENSR	Only available if external sensor is installed. Selects between Internal (I), External (E) and Averaging (A) control of Internal (thermostat) and External (remote indoor sensor) for temperature control. Attaching an outdoor sensor for outdoor temperature display or balance point control is automatically detected. Test outdoor sensor connection by pressing BACK and NEXT at the same time.
			IMPORTANT: At installation, Remote Indoor Sensor must be at room temperature.
13 Set Security Level for Keypad Lock	SEC 2	SEC 1, SEC 2	Selects between level 1 or level 2 keypad lockout.
14 Dead Band	bAND 3	bAND 2, bAND 3, bAND 4, bAND 5	Selects Auto Changeover Dead Band of 2, 3, 4, 5° F (1.0, 1.5, 2.0, 2.5° C). Only available if Auto Changeover is enabled in option 2.

Installer Options	Factory Default	Options	Comment
15 Compressor Balance Point	BALCN0	BALCN0, BALCN10, BALCN50	Scrolls between N0 (no lockout) and 10 to 50° F (-12 to 10° C) to set Compressor Balance Point. Only available with multi-stage heat pump and outdoor sensor connected.
16 Auxiliary Balance Point	BALRAN0	BALRAN0, BALRAN70, BALRAN40	Scrolls between N0 (no lockout) and 70 to 40° F (21 to 4° C) to set Auxiliary Balance Point. Only available with multi-stage heat pump and outdoor sensor connected.
17 Heating Set Point Upper Limit	HEAT90	HEAT90, HEAT60	Scrolls between 90 and 60° F (32 and 10° C).
18 Cooling Set Point Lower Limit	COOL45	COOL45, COOL80	Scrolls between 45 and 80° F (7 and 27° C).

Installer Option Descriptions

- Selects preferred temperature scale of either °F or °C.
- Selects Auto Changeover on or off. When off is selected, the AUTO icon will not be displayed when selecting the system options with the system switch. When Auto Changeover mode is enabled and selected, the system automatically switches between heating and cooling when the room temperature meets the programmed heating or cooling set points.
- Selects single stage conventional (11C), 2 stage conventional (22C), single stage heat pump (11HP), 2 stage heat pump (22HP), or 3 stage heat pump (32HP). Any change made to the system type resets Installer Options 4 through 8 to their default values dependent on system selected.
- Selects between 1st stage gas or electric heat Fan Control. This Installer Option is not available with a heat pump system.
- Selects aux-stage gas or electric heat Fan Control. This Installer Option is only available with a 2 or 3 stage heat pump system.
- For heat pump units with an electric auxiliary stage, both the first and second stages of heating will run when a call for second stage heat is made. For heat pump units with a fossil fuel auxiliary stage, the compressor stage(s) will be locked out one minute after a second stage heat call, and the second stage will only be used. **NOTE: Can be overridden by Auxiliary Balance Point. See Installer Option number 16 in the chart above for details.**
- Select between turning the AC power interrupt warning off or on. During a power loss, the thermostat will display an outage warning (-AC). All set points will be maintained until the outage period is over. This Installer Option is only available when thermostat is installed as a hardwired unit.
- This thermostat provides cold weather compressor protection by locking out the compressor stage (1st stage) of heating for a period of time after a power outage greater than 60 minutes. The lockout period is one hour less than the outage time, up to a maximum of 12 hours. During that period of time, the auxiliary heat stage will still be available to maintain the set point temperature. The compressor lockout can be disabled by setting this option to OFF (*continued on page 8*).

Installer Option Descriptions *continued*

- This thermostat includes an automatic compressor protection feature to avoid potential damage to the compressor from short cycling. This thermostat automatically provides an adjustable delay after turning off the compressor. This protection is also present in the first stage heat mode of operation on single stage heat pump systems to protect the compressor.
- During the COOL mode of normal operation the fan will stay on for 60 seconds after the cooling system has satisfied the set point temperature and has turned off the compressor. This allows the system to provide higher efficiency during cooling operation. The delay is selectable between 0, 30, 60 or 90 seconds.
- The Recirculating Fan Mode provides more even temperature distribution and improves indoor air quality by circulating air through the furnace filtration system more often. The Recirculating Fan can be locked "on", so that the only fan selections available to the user are CIRC and ON. By locking the Recirculating Fan to CIRC/ON, the user will only have the option to run the fan all the time (ON) or use the Recirculating Fan Feature (CIRC). When locked on, the fan circulates at a fixed time of 12 minutes on, 24 minutes off. In the CIRC mode, the fan can be set to run every 24, 40, 60 or 120 minutes (see chart below). The Recirculating Fan feature is available in the COOL, OFF, HEAT, or EMER mode. To set the fan run time, see page 12.

Fan Cycle Setting	Fan Off Time (minutes)	Fan Run Time (minutes)
24	24	12
40	40	12
60	60	12
120	120	12

- If a Braeburn® indoor or outdoor remote sensor is connected during installation, the thermostat will automatically detect the type of sensor. When an indoor sensor is detected, you may select between internal (sensI), external (sensE), or averaging (sensA) of internal and external for temperature control. When an outdoor sensor is automatically detected, the thermostat will remove the choices for indoor sensing from the menu and enable outdoor measurement. The outdoor sensor may be used to determine if balance points have been exceeded, and for outdoor temperature display. For proper auto-detection, you must use a Braeburn brand external sensor. Should the external sensor become unwired, the thermostat will retain the settings, but the balance points, temperature dependent humidity control, and outdoor temperature display will be disabled until the external sensor is repaired. Test the operation of the external sensor by pressing the **BACK** and **NEXT** buttons at the same time.

Option Settings	Temperature Control
sens I (Internal Thermostat Sensor)	At Thermostat
sens E (Remote Indoor Sensor)	At Remote Sensor
sens A (Internal and Remote)	Average between Internal and Remote

4 Programming Installer Settings *cont.*

Installer Option Descriptions *continued*

- The keypad lockout feature has two levels of security. Level one locks all buttons (including the reset) except for the **▲**, **▼** and backlight buttons. Level two locks the entire keypad except the backlight button. The **▲** and **▼** buttons can be pressed together to enter the lock code but the buttons do not work individually to adjust the temperature. The lock security level is set in the Installer Options and the lock code is set in the User Options.
- When Auto Changeover mode is enabled and selected, the system automatically switches between heating and cooling when the room temperature meets the normal criteria for either a heating or cooling call. There is a forced separation (dead band) between the heating and cooling set points, so the systems do not work against each other. This option selects Auto Changeover Dead Band of 2°, 3°, 4° or 5° F. The default is 3° F.
- Only available with multi-stage heat pump and outdoor sensor connected. Locks out the use of the compressor heat stage for outside air temperatures less than installer setting. Select from no lockout or a setting between 10° F to 50° F (-9° C to 10° C).
- Only available with multi-stage heat pump and outdoor sensor connected. Locks out the use of the auxiliary heat stage for outside air temperatures over installer setting. Select from no lockout or a setting between 70° F to 40° F (21° C to 4° C). **NOTE:** *This balance point overrides the fossil fuel compressor lockout. If the lockout is set to AG and the outdoor temperature is over the AUX balance point, the compressor will remain on during a second stage heating call. The unit will recover to the set point without the AUX stage.*
- Selects the heating set point upper limit, scrolls between 90° F and 60° F (32° C and 10° C).
- Selects the cooling set point lower limit, scrolls between 45° F and 80° F (7° C and 27° C).

5 Programming User Settings

Setting Temperature Differentials

The default settings for the first, second and third stage differentials are compatible with most systems and applications. This is normally set at time of installation and usually does not require any modification under normal operating conditions. If you feel that your system is turning on too often, simply follow the instructions below.

NOTE: *The temperature differential settings are the same for both the heating and cooling systems. Depending on the HVAC system installed, D2 or D3 may not appear.*

Setting First Stage Differential

The default setting is 0.2° F (0.1° C). The room temperature must change 0.2° F (0.1° C) from the set point temperature before the thermostat will initiate the system in heating or cooling.

- In normal operating mode, press and hold the **NEXT** button for 4 seconds. The LCD display will show “**SET D1 X[°]**”, where “**X**” equals the °F / °C differential setting. This is the current first stage differential setting.

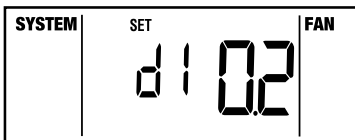

9

5 Programming User Settings *cont.*

- Press the **▲** or **▼** buttons to set the first stage differential to your desired setting of 0.2°, 0.5° or 1° F (0.1°, 0.3° or 0.5° C).
- For Two Stage Systems:** Press the **NEXT** button again to change the second stage setting or wait 30 seconds for the thermostat to return to the normal operating mode.

Setting Second Stage Differential

The default setting is 2° F (1.0° C). The room temperature must change 2° F (1.0° C) in addition to the first stage differential setting before the thermostat will initiate the second stage of the system in heating.

- Press the **▲** or **▼** buttons to set the second stage differential to your desired setting of 2°, 3°, 4°, 5° or 6° F (1°, 1.5°, 2°, 2.5° or 3° C).

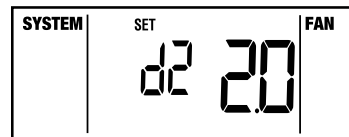

- For Three Stage Systems:**

Press the **NEXT** button again to change the third stage setting or wait 30 seconds for the thermostat to return to the normal operating mode.

Setting Third Stage Differential

The default setting is 2° F (1.0° C). The room temperature must change 2° F (1.0° C) in addition to the first and second stage differential setting before the thermostat will initiate the third stage of the system in heating.

- Press the **▲** or **▼** buttons to set the third stage differential to your desired setting of 2°, 3°, 4°, 5° or 6° F (1°, 1.5°, 2°, 2.5° or 3° C).

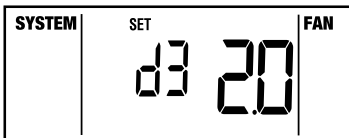

- Press **NEXT** to change the filter check monitor, or wait 30 seconds for the thermostat to return to the normal operating mode.

Setting the Filter Check Monitor (see description in section 6)

The default setting is 0 days (monitor disabled).

- Press and hold the **NEXT** button for four seconds. Press **NEXT** repeatedly until “**SET XXX FILTER**” is displayed where “**XXX**” is the Filter Monitor interval.

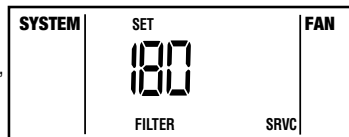

- Press the **▲** or **▼** button to change the Filter Monitor Interval to the desired value of 0 (disabled), 30, 60, 90, 120, 180 or 365 days.

Setting the UV Light Monitor (see description in section 6)

The default setting is 0 days (monitor disabled).

- Press and hold the **NEXT** button for four seconds. Press **NEXT** button repeatedly until “**SET XXX UV**” is displayed where “**XXX**” is the UV Light Monitor interval.

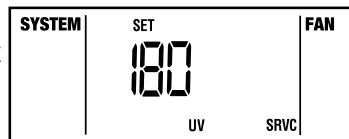

- Press the **▲** or **▼** button to change the UV Light Monitor Interval to the desired value of 0 (disabled), 180 or 365 days.

10

5 Programming User Settings *cont.*

Setting the Humidifier Pad Monitor (see description on page 13)

The default setting is 0 days (monitor disabled).

- Press and hold the **NEXT** button for four seconds. Press **NEXT** button repeatedly until “**SET XXX HUMID**” is displayed where “**XXX**” is the Humidifier Pad Monitor interval.

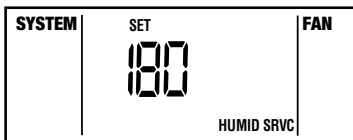

- Press the **▲** or **▼** button to change the Humidifier Pad Monitor Interval to the desired value of 0 (disabled), 180 or 365 days.

Keypad Lockout

This thermostat is equipped with a Multi-Level Keypad Lockout feature which can be used to prevent undesired adjustment of the set point and/or programs. Lock security level 1 locks all the buttons (including the reset button) except for the **▲**, **▼** and backlight buttons. Lock security level 2 (default) locks the entire keypad except for the backlight button [see Installer Option 13 in Section 4 for information on setting lock security levels].

Setting Your Lock Code

Press and hold the **NEXT** button for 4 seconds to enter into the User Settings Mode. Press the **NEXT** button repeatedly until **LOCK, SET** and 3 digits are displayed. Use the **▲** or **▼** buttons to adjust the first digit, press the **NEXT** button to move to the second digit and repeat the process until you have entered all 3 digits. Once complete, you can press the **BACK** and **NEXT** buttons together or wait 30 seconds for the thermostat to return back to the main screen. The thermostat is now ready to be locked with the 3 digit code you have created.

Locking the Thermostat

Press and hold the **▲** and **▼** buttons together for five seconds. While you are holding these buttons the **LOCK** icon will flash once per second and after 5 seconds the **LOCK** icon and three digits will



appear in the display. Use the **▲** or **▼** buttons to enter the lock code you previously created (see “Setting Your Lock Code”). After entering the first digit, press the **NEXT** button to move to the second digit and repeat this process until you have entered all 3 digits. Once you complete entry of the third digit, the thermostat will be locked and will automatically return to the main screen and display the **LOCK** icon. If you enter an incorrect three digit lock code, “no” will appear in the display and you will have to repeat the process.

Unlocking the Thermostat

To unlock the thermostat, perform the exact same steps that you took to lock it. Once your 3 digit lock code is successfully entered, the thermostat will be unlocked and **LOCK** will no longer appear in the display. If you enter an incorrect three digit lock code, “no” will appear in the display and you will have to repeat the process.

5 Programming User Settings *cont.*

Recirculating Fan Mode

The Recirculating Fan Mode provides more even temperature distribution and improves indoor air quality by circulating air through the furnace filtration system more often. The Recirculating Fan Mode can be selected by changing the fan option to recirculate (**CIRC**) by pressing the **FAN** button. If no call for heating or cooling occurs within the fan off cycle (see page 8), the fan will run for 12 minutes. The highest setting, 120 minutes, will run the fan once every 2 hours. The lowest setting, 24 minutes (factory default), will run the fan every 24 minutes. During any call for heating or cooling, fan control operates in the AUTO mode. This feature is available in the HEAT, OFF, COOL or EMER mode.

Setting the Recirculating Fan Cycle

- Press and hold the **NEXT** button for four seconds. Press **NEXT** button repeatedly until “**SET XXX OC**” is displayed where “**XXX**” is the Recirculating Fan off cycle.

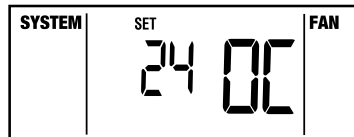

- Press the **▲** or **▼** button to change the Recirculating Fan off cycle to the desired value of 120, 60, 40 or 24 minutes.
- Press the **NEXT** button again to return to the normal mode, or wait 30 seconds for the thermostat to return automatically.

Setting the Recirculating Fan Cycle

Fan Cycle Setting	Fan Off Time (minutes)	Fan Run Time (minutes)
24	24	12
40	40	12
60	60	12
120	120	12

6 Additional Operation Features

Changing Set Temperature

- Press and hold **▲** or **▼** button for more than 1 second. The entire display will flash once and the **SET** indicator will be flashing. Release the **▲** or **▼** button and press the **▲** or **▼** button again to adjust the set temperature.

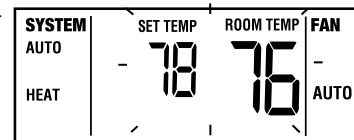

- The display will return to normal operating mode after 15 seconds, or you can press the **BACK** button to return to normal operating mode.

NOTE: Select either **COOL** or **HEAT** with the system button to view or change cooling or heating set points.

Filter Check Monitor

The Filter Check Monitor displays a reminder for required filter replacement or cleaning, by flashing the **FILTER** segment in the display. See instructions on your filter or heating/cooling unit for recommendations for interval setting. When the selected interval has been reached, and required cleaning or replacement has been performed, press the **BACK** button in any normal mode to reset the timer and turn off the warning.

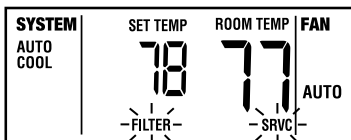

UV Light Monitor

The UV Light Monitor displays a reminder for required replacement of the bulb by flashing the UV segment in the display. See instructions provided with your UV source for recommendations on interval setting. When the selected interval has been reached and required replacement has been performed, press the **BACK** button in any normal mode to reset the timer and turn off the warning.

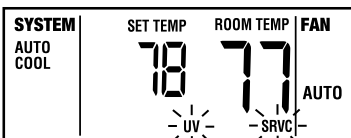

Humidifier Pad Monitor

The Humidifier Pad Monitor displays a reminder for required replacement of the humidifier pad by flashing the **HUMID SRVC** segment in the display. See instructions on your filter or heating/cooling unit for recommendations for interval setting. When the selected interval has been reached, and required service has been performed, press the **BACK** button in any normal mode to reset the timer and turn off the warning.

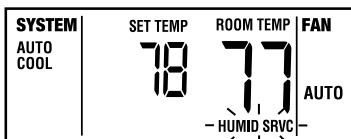

Compressor Protection Feature

This thermostat includes an automatic compressor protection feature to avoid potential damage to the system from short cycling. This thermostat automatically provides an adjustable (5-minute default) delay after turning off the compressor. This protection is also present in the first stage heat mode of operation on heat pump systems to protect the compressor.

NOTE: The installer can bypass the compressor protection feature by pressing the **RESET** button located on the front of the thermostat. This will return all User Settings and the set point temperature back to their default values. The Installer Settings are not affected.

Low Battery Detection and Replacement

This thermostat requires two (2) properly installed "AA" alkaline batteries to provide power for the thermostat if 24 volt AC power is not connected to the terminal block.

This thermostat is equipped with a unique, three level low battery detection feature that constantly monitors the batteries during normal operating mode to determine whether they have sufficient power to provide proper operation. When this feature determines that the battery status is low, a low battery indicator will appear in the display. After 30 days the battery indicator will start to flash, and after 60 days the battery indicator will begin to flash faster, indicating that the batteries need to be replaced immediately to maintain system operation and program settings.

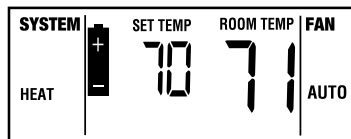

Replacing the Batteries

1. Open the front cover and locate the battery compartment door.
2. Remove the two "AA" alkaline batteries located in the battery compartment.
3. Install two new "AA" alkaline batteries into battery compartment. Make sure to match the positive (+) ends of the batteries with the positive (+) terminals located in the battery compartment.
4. Close battery compartment. The low battery indicator should no longer appear in the display.

Non-Volatile Memory

In the event of a power failure or battery removal, the Non-Volatile Memory feature allows all settings to be recovered, eliminating the need to reset temperature and various user/installer settings. When AC power is restored after an outage or batteries are reinserted, all settings are retrieved from memory and reinstated.

Status Indicators

Three status indicators can be displayed to notify you of key system information.

AUX: This will turn on when the auxiliary stage of heating is active. The auxiliary stage of heating is usually the least economical stage of heat.

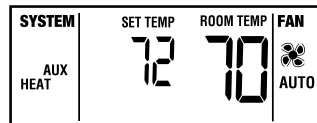

CHECK: Indicator will be displayed when a malfunction occurs in a heat pump system. When this indicator is active, call a professional service technician to verify system performance and switch the system to Emergency Heat mode if required to maintain room temperature.

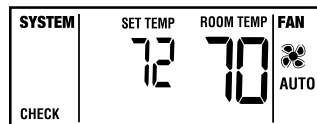

EMER (displays only on heat pump systems): Indicator will be displayed when Emergency Heat Mode of operation is selected using the system selector button. When selected, the heat pump stage of heat is turned off and the emergency (auxiliary) stage of heating is used to maintain the set point temperature.

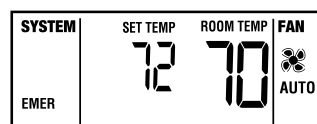

7 Testing the Thermostat

WARNING! Read *BEFORE* Testing

- Do not short (or jumper) across terminals on the gas valve or at the heating or cooling system control board to test the thermostat installation. This could damage the thermostat and void the warranty.
- Do not select COOLING test modes if the outside temperature is below 50° F (10° C). Doing so could possibly damage the compressor system and may cause personal injury.
- This thermostat includes an automatic compressor protection feature that is DISABLED during test mode. When testing, DO NOT quickly switch the compressor on, off and on. Doing so could possibly damage the compressor system and may cause personal injury.

This thermostat features a menu driven operational test mode. This test mode is intended for use by trained HVAC technicians. If you are unfamiliar with the operation of this equipment, please contact a qualified service technician to perform these tests.

To START TEST MODE, Press **BACK** and **▲** at the same time for 3 seconds.
To EXIT TEST MODE, Press **BACK** and **▶** at the same time for 3 seconds.
To NAVIGATE TEST MODE, Press **NEXT** to move forward to the next test type. Press **BACK** to move back to the previous test. Press **▲** to start and stop each test. To EXIT TEST MODE, Press **BACK** and **▶** at the same time for 3 seconds.

Test Type	System Function	System Type	Active Terminals
Cooling	1st Cooling Stage	Conventional or Heat Pump	Y1, O, G
Cooling	2nd Cooling Stage	Conventional or Heat Pump	Y1, Y2, O, G
Heating	1st Heating Stage	Conventional	W1, B, G*
Heating	1st Heating Stage	Heat Pump	Y1, B, G
Heating	2nd Heating Stage	Conventional	W1, W2, B, G*
Heating	2nd Heating Stage	2 Stage Heat Pump	Y1, W2, B, G
Heating	2nd Heating Stage	3 Stage Heat Pump	Y1, Y2, B, G
Heating	3rd Heating Stage	3 Stage Heat Pump	Y1, Y2, W3, B, G
Heating	Emergency Heat	2 or 3 Stage Heat Pump	E, B, G*
Fan	Fan Only	Conventional or Heat Pump	G

To provide time to verify equipment operation, a test will run for 5 minutes. At the end of that time, the thermostat will return to normal operating mode. To stop a test early press **BACK** and **▶** at the same time for 3 seconds.

NOTE: Only tests that apply to the current thermostat settings will be displayed. As an example, tests for 3rd stage compressor will not be available on a thermostat configured for a 2 stage conventional system.

*Notes on Fan (G Terminal) Function: The G terminal will only be active if the stages are configured as electric heat. Systems that have the heating stages configured as gas will not activate the fan (G) terminal.

8 Troubleshooting

Symptom: Thermostat does not turn on heating or cooling system.

Potential Solution: Check to see if **OFF** is shown in display. This indicates that the system is turned off at the thermostat. Change the system to **HEAT** or **COOL**. After the compressor short cycle protection period expires, the system should start.

Compressor protection feature may be in effect due to compressor short cycle conditions. See page 13.

Heating or cooling system may be malfunctioning. Call a professional service technician immediately to verify system operation.

Symptom: Thermostat turns on heating instead of cooling or cooling instead of heating.

Potential Solution: Check thermostat wiring to make sure that the heating and cooling stages are connected to the correct terminals on the wiring terminal block. See section 9, *Wiring Diagrams*.

Symptom: Thermostat turns heating or cooling system on too often or not often enough.

Potential Solution: Increase or decrease temperature differential settings as appropriate to provide the desired performance level. See page 9.

Symptom: Low battery indicator is shown in thermostat display.

Potential Solution: Replace batteries immediately to maintain proper system operation. See page 14.

Symptom: Thermostat display is blank.

Potential Solution: It is possible that AC power is not present at the thermostat and/or the batteries are drained. Check fuse, circuit breaker and thermostat wiring as appropriate to verify AC power is available. Replace batteries before reprogramming thermostat. See page 14. If AC power is present, call a professional service technician to verify thermostat and system performance.

Symptom: The room is too warm or too cold.

Potential Solution: Review current set point and change as necessary. See page 12.

Symptom: Fan runs intermittently or when system is off.

Potential Solution: Fan switch is in Recirculate Mode (**CIRC**).

Symptom: HI is shown in the thermostat display.

Potential Solution: The temperature sensed by the thermostat is higher than the 99° F (37° C) upper limit of the thermostats display range. The display will return to normal after the sensed temperature lowers within the 40° to 99° F (4° to 37° C) display range. Turn on the cooling system or use other methods to lower the temperature accordingly.

This condition could occur from the system being turned off during an exceptionally warm period or upon installation when the thermostat has been stored for a long period of time in a warm vehicle or location prior to being installed.

Symptom: LO is shown in the thermostat display.

Potential Solution: The temperature sensed by the thermostat is lower than the 40° F (4° C) lower limit of the thermostat's display range. The display will return to normal after the sensed temperature rises within the 40° to 99° F (4° to 37° C) display range. Turn on the heating system to raise the temperature as needed for comfort within the room.

This condition could occur from the system being turned off during a cold weather period or upon installation when the thermostat has been stored for a long period of time in a cold vehicle or location prior to being installed. The thermostat should be allowed to warm up prior to installation in order to provide proper heating control once installed.

8 Troubleshooting *cont.*

Symptom: *Cannot program a set point temperature higher than 90° F (32° C).*

Potential Solution: This is above the normal thermostat temperature setting range of 45° to 90° F (7° to 32° C).

Symptom: *Cannot program a set point temperature lower than 45° F (7° C).*

Potential Solution: This is below the normal thermostat temperature setting range of 45° to 90° F (7° to 32° C).

Symptom: *Thermostat will not allow me to change the set point.*

Potential Solution: The keypad is locked. Press and hold the **▲** and **▼** buttons at the same time to enter unlock mode. Press **▲** to enter the 3 digit unlock code. Press the **NEXT** button to move to the next digit.

Symptom: *Fan continues to run all the time whether the system is on or off.*

Potential Solution: Check to make sure the fan control switch is in the AUTO position. This will allow the fan to run only when the heating or cooling system is turned on and running.

Check thermostat wiring to make sure that the fan control wiring is connected to the correct terminals on the wiring terminal block. See section 9, *Wiring Diagrams*.

Symptom: *CHECK is shown in thermostat display.*

Potential Solution: Switch to emergency heat if heat is required. Contact a professional service technician to verify thermostat and system performance.

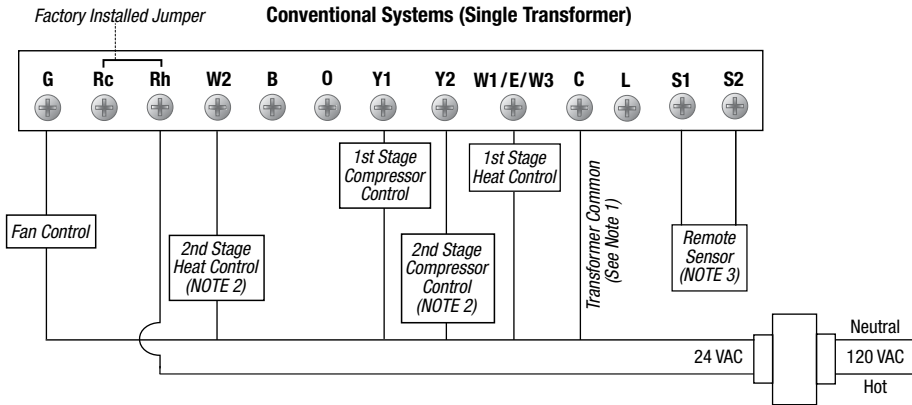

- NOTES:**
1. Transformer Common connection not required for battery-only operation of thermostat.
 2. Second Stage Control connections not used for single stage heating or cooling systems.
 3. Remote Sensor Terminals can be either for Outdoor or Indoor Remote Sensor depending on installer settings.
 4. For millivolt or other 2 wire heating systems, connect wires from heating control to Rh and W1.

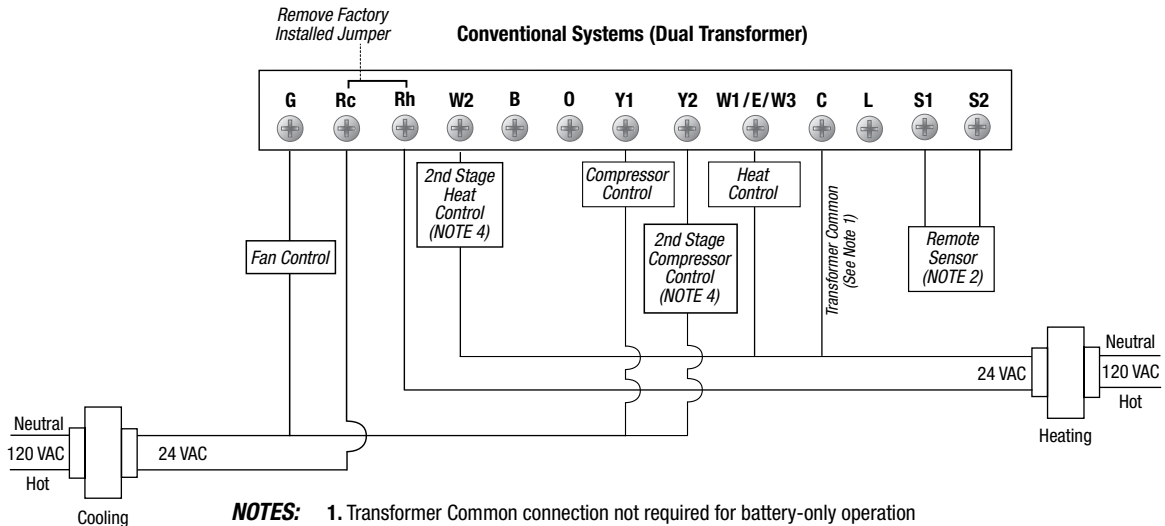

- NOTES:**
1. Transformer Common connection not required for battery-only operation of thermostat.
 2. Remote Sensor Terminals can be either for Outdoor or Indoor Remote Sensor depending on installer settings.
 3. For millivolt or other 2 wire heating systems, connect wires from heating control to Rh and W1.
 4. Second Stage Control connections not used for single stage heating or cooling systems.

One and Two Stage Heat Pump Systems

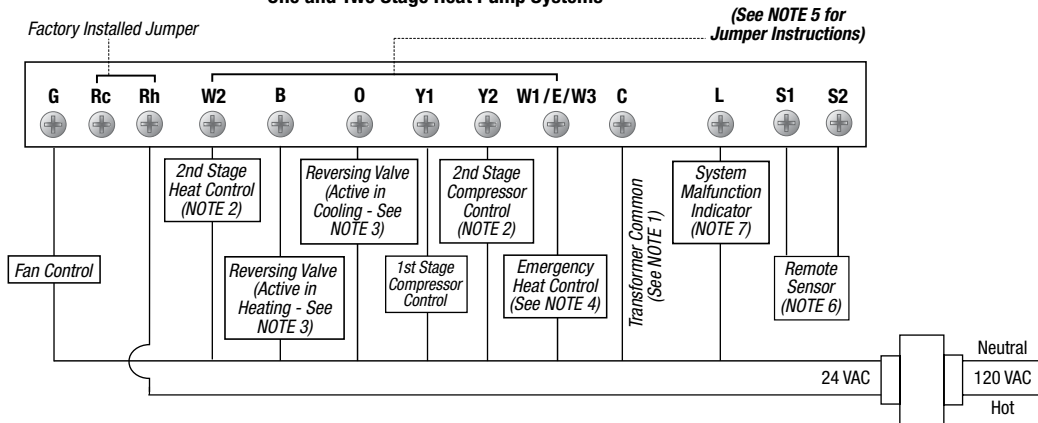

- NOTES:**
1. Transformer Common connection not required for battery-only operation of thermostat.
 2. Second Stage Control connections not used for single stage heating or cooling systems.
 3. For units requiring reversing valve to be energized during heating, connect reversing valve to B terminal. For units requiring reversing valve to be energized during cooling, connect reversing valve to O terminal.
 4. Required for units with 2 stage heat only.
 5. For 2 stage heat units not having a separate Emergency Heat Terminal, add installer supplied jumper.
 6. Remote Sensor Terminals can be either for Outdoor or Indoor Remote Sensor depending on installer settings.
 7. If L Terminal is used, 24VAC common (C terminal) must be connected.

Three Stage Heat Pump Systems

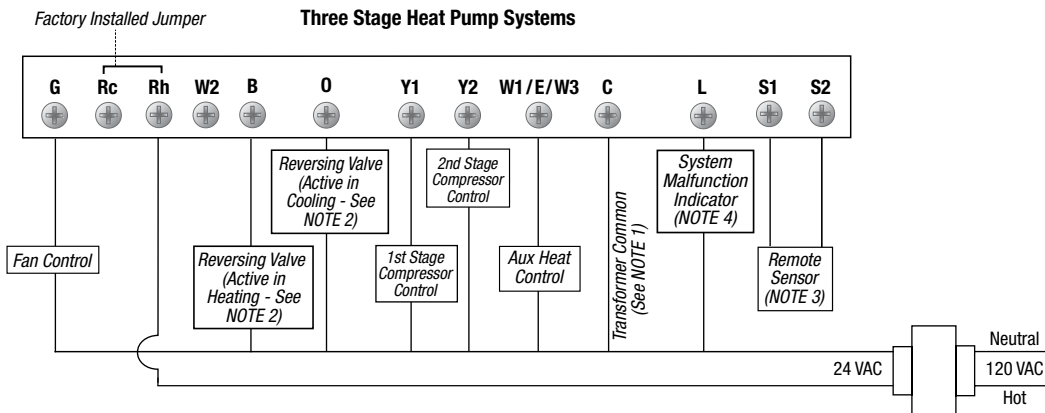

- NOTES:**
1. Transformer Common connection not required for battery-only operation of thermostat.
 2. For units requiring reversing valve to be energized during heating, connect reversing valve to B terminal. For units requiring reversing valve to be energized during cooling, connect reversing valve to O terminal.
 3. Remote Sensor Terminals can be either for Outdoor or Indoor Remote Sensor depending on installer settings.
 4. If L Terminal is used, 24VAC common (C terminal) must be connected.

Braeburn®

5 YEAR
LIMITED
WARRANTY



**Store this
booklet for
future reference**

Braeburn Systems LLC warrants each new Braeburn thermostat against any defects that are due to faulty material or workmanship for a period of five years after the original date of purchase by a professional service technician. This warranty and our liability does not apply to batteries, nor does it include damage to merchandise or the thermostat resulting from accident, alteration, neglect, misuse, improper installation or any other failure to follow Braeburn installation and operating instructions.

Braeburn Systems LLC agrees to repair or replace at its option any Braeburn thermostat under warranty provided it is returned postage prepaid to our warranty facility in a padded carton within the warranty period, with proof of the original date of purchase and a brief description of the malfunction. This limited warranty does not include the cost of removal or re-installation.

This warranty gives you specific legal rights and you may also have other rights that vary from state to state or province to province. Answers to any questions regarding our limited warranty may be obtained by writing our corporate offices.

WARRANTY FACILITY: Braeburn Systems LLC
Attn: Warranty Department
2215 Cornell Avenue
Montgomery, IL 60538

Braeburn®

Braeburn Systems LLC
2215 Cornell Avenue • Montgomery, IL 60538
Technical Assistance: www.braeburnonline.com
Call us toll-free: 866-268-5599 (U.S. Only)
630-844-1968 (Outside the U.S.)

©2009 Braeburn Systems LLC • All Rights Reserved • Made in China
U.S. Patents D524,663; D536,271; 7,438,469 • No. 3300-100-004